

## Manifolds - Five Valve

A three or five valve harness manifold for use with orifice meters in natural gas service at pressures to 6000 psig (414 barg)

### General Application

The three-valve manifold is used when the orifice meter is mounted adjacent to the orifice flange and the two process block valves provide convenient closure. The five-valve assembly is for orifice meters remote from the orifice flange union

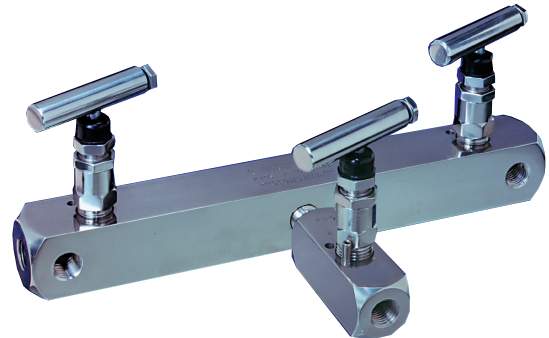

### TECHNICAL DATA

**Materials**

CS, 316 SS

**Seats:**

Soft

**Connections:** Pipe x pipe

**Instrument:** 1/4" NPT

**Process:** 1/4" NPT

**Pressure (max):**

6000 psig (414 barg)

**Temperature range (max):**

400°F (204°C)

### Features

- Soft seat replaceable valve operates in dirty service with repetitive bubble-tight shutoff.
- Packing below threads prevents lubricant washout, thread corrosion, process contamination and eliminates galling.
- Easily adjustable PTFE packing decreases replacement downtime and increases valve life.
- Dust cover protects stem from lubricant contamination.
- Safety back seating prevents stem blowout or accidental removal and provides a metal-to-metal secondary stem seal while in the fully open position.
- ENC plated 316 SS stem prevents galling or freezing of stem threads. CS valves use a 303 SS stem for 'hard-to-soft' contact, to prevent galling.
- Rolled stem and bonnet threads provide additional strength.
- Mirror stem finish in the packing area provides smooth operation and extends packing life.
- Straight-through flow path means high flow capacity, bi-directional flow and rodding capabilities.
- Metal-to-metal body-to-bonnet seal in constant compression prevents bonnet thread corrosion, eliminates possible tensile breakage and gives a reliable seal point.

# M19 SERIES

## Manifolds - Five Valve

### M19 Dimensions

Dimensions, inches (mm)

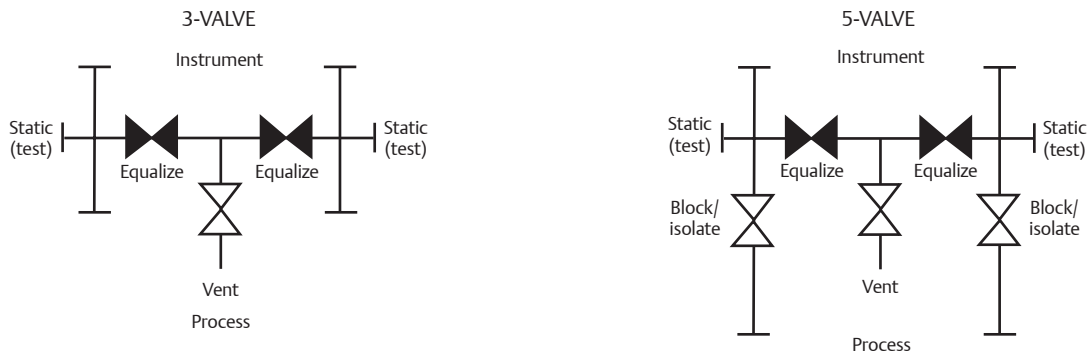
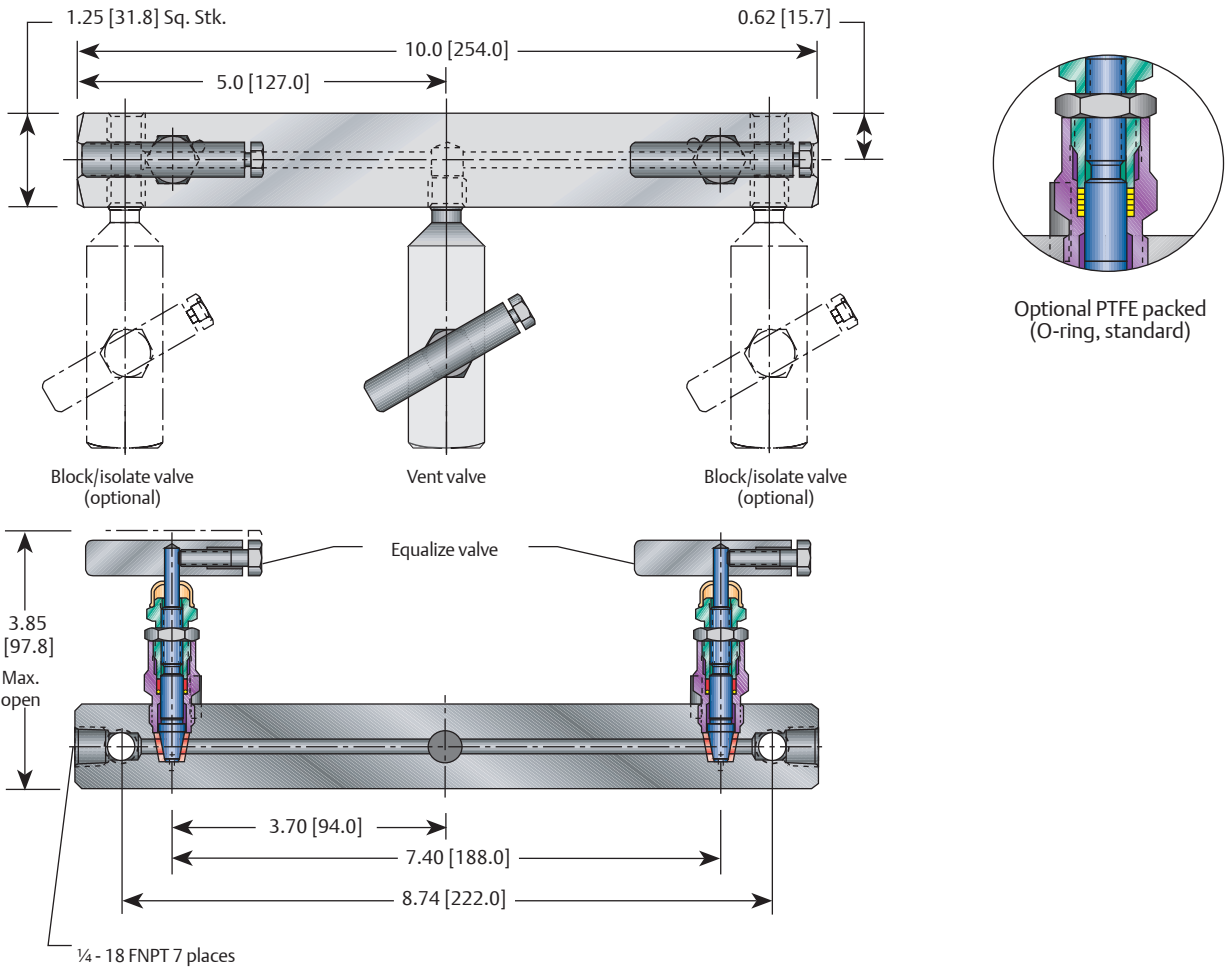

**NOTE**

1. Approximate valve weight: 5.5 lb [2.4 kg], 8.0 lb [3.6 kg] with optional block valves. 0.187-inch [4.8 mm] diameter orifice. Valve Cv 0.83 maximum.

## Manifolds - Five Valve

### Bonnet Assemblies

The roddable soft-seated bonnet assemblies have a one-piece rotating stem and plug. The stem threads are rolled and lubricated to prevent galling and reduce operating torque. They are available with a FKM O-ring and PTFE back-up ring or a patented PTFE packing gland, which is adjustable in service. A protective dust cap is fitted to contain stem lubricant and prevent the influx of contaminants. All bonnets are assembled with a bonnet locking pin to prevent accidental removal while in service.

### Standard Materials

Valve	Body	Bonnet	Stem	Packing	Seat <sup>[1]</sup>
CS <sup>[2]</sup>	A108 CS	A108 CS	A581-303 SS	FKM O-ring with PTFE backup ring	Delrin <sup>®</sup>
316 SS	A479-316 SS	A476-316 SS	A276-316 SS	FKM O-ring with PTFE backup ring	Delrin <sup>®</sup>
SG <sup>[3]</sup>	A479-316 SS	A479-316 SS	Monel <sup>®</sup> R405	PTFE	Delrin <sup>®</sup>

### Pressure and Temperature Ratings

Seat	Ratings
Delrin <sup>®</sup>	6000 psig at 200°F [414 barg at 93°C]
PEEK	6000 psig at 200°F [414 barg at 93°C] 2000 psig at 400°F [138 barg at 204°C]
PTFE	1000 psig at 150°F [69 barg at 66°C] 200 psig at 500°F [14 barg at 260°C]

### Minimum temperature

Carbon steel:	-20°F [-29°C]
316 SS O-ring seal:	-20°F [-29°C]
316 SS PTFE Packed:	-70°F [-57°C]

### NOTES

1. PCTFE (Polychlorotrifluoroethylene is exact equivalent of Kel-F<sup>®</sup>), PEEK and PTFE are available.
2. CS is zinc TCP plated to prevent corrosion.
3. SG (Sour Gas) Meets the requirements of NACE MRO175/ISO15156 (for chloride conditions <\_ 50 mg/l (ppm)) and NACE MRO103-2005.
4. Also available with PTFE packing.

### Pressure vs. Temperature

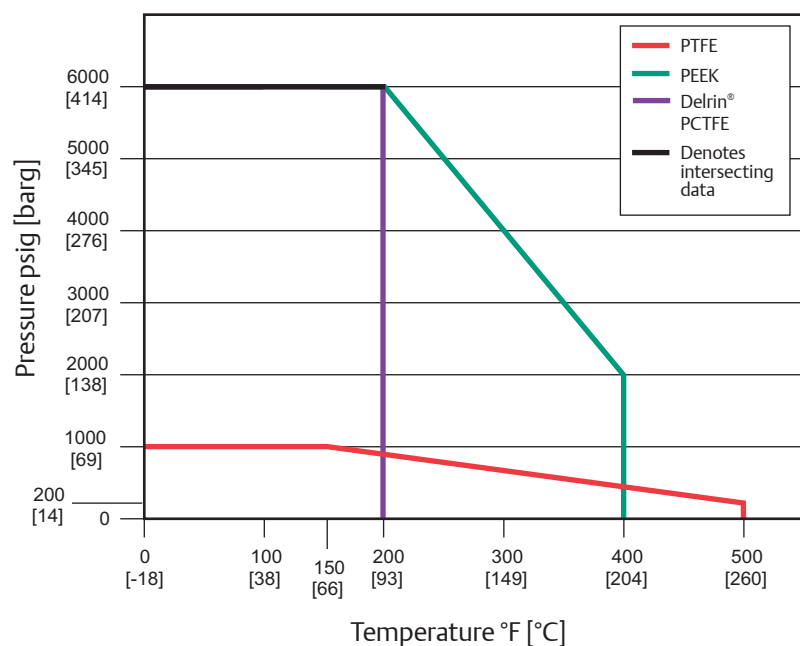

# M19 SERIES

## Manifolds - Five Valve

### Selection Guide

M19	C	T	-H1	-SG
BASIC SERIES	MATERIALS OF CONSTRUCTION	CONFIGURATION	VENT VALVE AND BLOCK TYPE	OPTIONS
M19	C CS, A108	T Three-valve	H1	CL00 Cleaned for chlorine service
	S SS, A479-316	F Five-valve	H5	OC00 Cleaned for oxygen service
				HD Hydrostatic testing (100 percent) (MSS SP-61)
				MS Monel® stem
				SG Sour Gas meets the requirements of NACE MR0175/ISO 15156 (for chloride conditions ≤ 50 mg/l (ppm)) and NACE MR0103-2005 (SS only)